

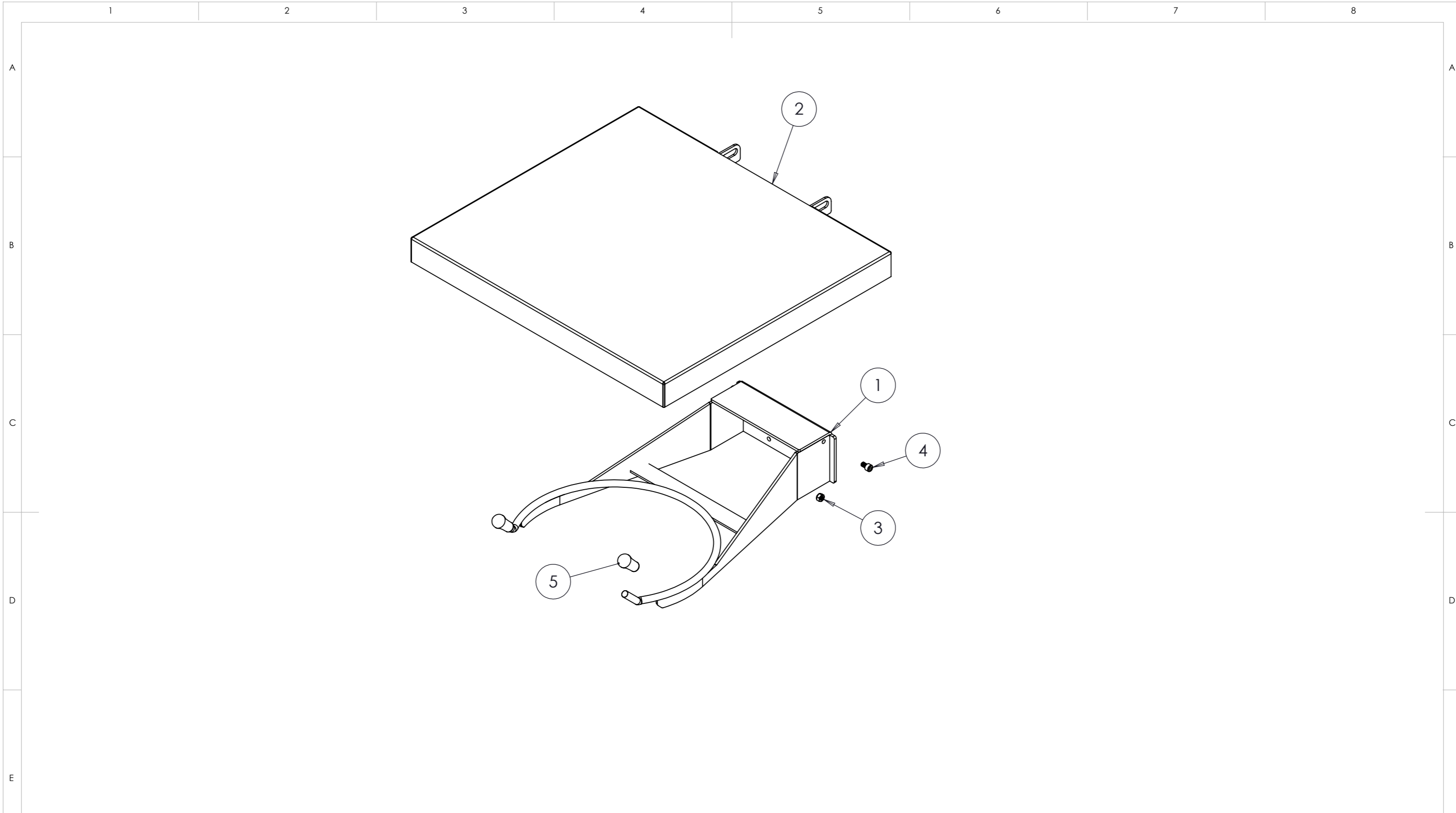

ITEM NO.	PART NUMBER	DESCRIPTION	Default/QTY.	Revision
1	40001668	Gaffel for køkkenlift svejst	1	2
2	30003207	Plade svejs køkkenlift	1	4
3	81020048	Lock nut M6 A2 DIN 985	2	
4	81010364	Screw M6x10 CH A2 DIN 912	2	
5	30008194	Dupsko til kedelgaffel, 10mm	2	1

UNLESS OTHERWISE SPECIFIED: DIMENSIONS ARE IN MILLIMETERS AND WITH TOLERANCES AFTER DS/ISO 2768-1 MIDDLE	FINISH:	EP	DEBUR AND BREAK SHARP EDGES	DO NOT SCALE DRAWING	Revision: 3
	<b>HOVMAND</b>				
TITLE: Bowl fork 30-60L Emma 3					
Emma					
MATERIAL:	DWG NO.		40010061	A3	
WEIGHT: 7.54 Kg			DRAWN BY: LL	Date[yy.mm.dd]:	SHEET 1 OF 2





ITEM NO.	PART NUMBER	DESCRIPTION	Default/QTY.
1	40001668	Gaffel for køkkenlift svejst	1
2	30003207	Plade svejs køkkenlift	1
3	81020048	Lock nut M6 A2 DIN 985	2
4	81010364	Screw M6x10 CH A2 DIN 912	2
5	30008194	Dupsko til kedelgaffel, 10mm	2

UNLESS OTHERWISE SPECIFIED: DIMENSIONS ARE IN MILLIMETERS AND WITH TOLERANCES AFTER DS/ISO 2768-1 MIDDLE	FINISH:	EP	DEBUR AND BREAK SHARP EDGES	DO NOT SCALE DRAWING	Revision: 3
	<b>HOVMAND</b>				
TITLE:		Bowl fork 30-60L Emma 3			
		Emma			
MATERIAL:	DWG NO.	40010061		A3	
				1:10	
WEIGHT: 7.54 Kg	DRAWN BY: LL	Date[yy.mm.dd]:	SHEET 2 OF 2		