

Lifting Stroke: ▲ 1245

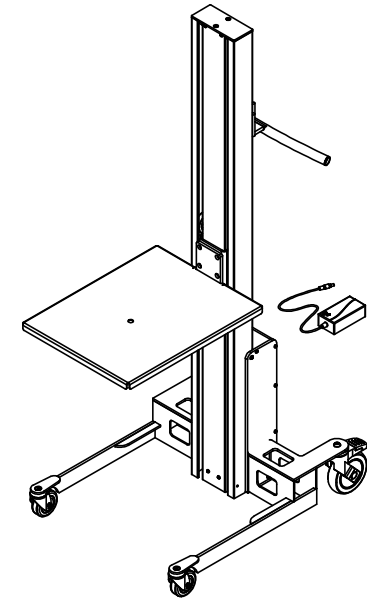
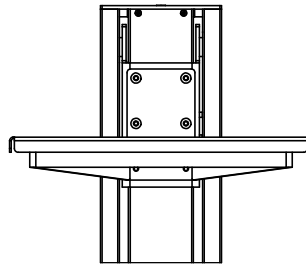

The lift can be ordered with different fixed heights: H, M, L

Add or subtract the ▲-values on the drawing with the number below:

M: +400
L: 0
S: -295

The tool is fixed.

The T-values on the drawing show the maximum and minimum lifting position for the tool.

EP1

| | | | |
|---------------------------------|----------------------------|----------------|-------------------------|
| FINISH: | Dimensions: +/- 5 mm | HOVMAND | |
| TITLE: Impact 70L Box-75s + EP1 | | | |
| MATERIAL: | DWG NO. 100205000000 + EP1 | Revision: 1 | |
| WEIGHT: 39.39 Kg | | DRAWN BY: KKP | Date[yy.mm.dd]:20.05.13 |

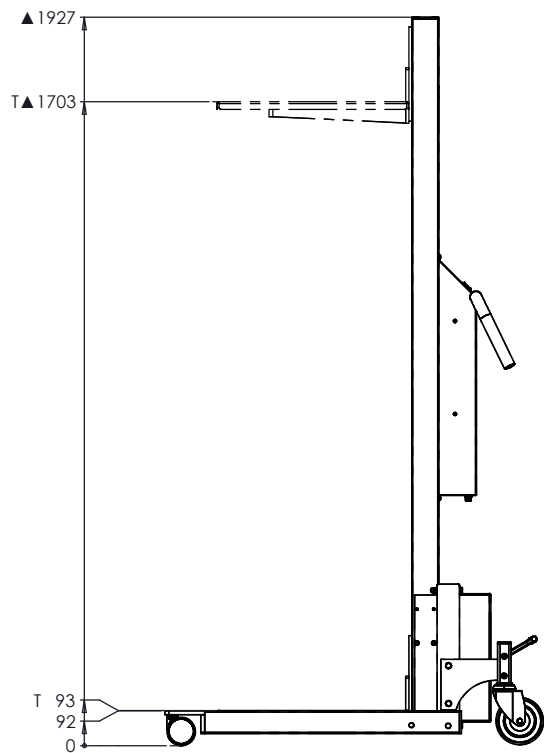

Lifting Stroke: ▲ 1610

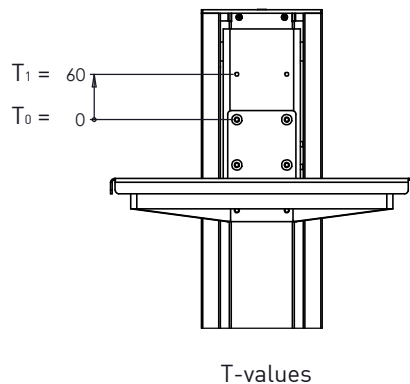

T-values

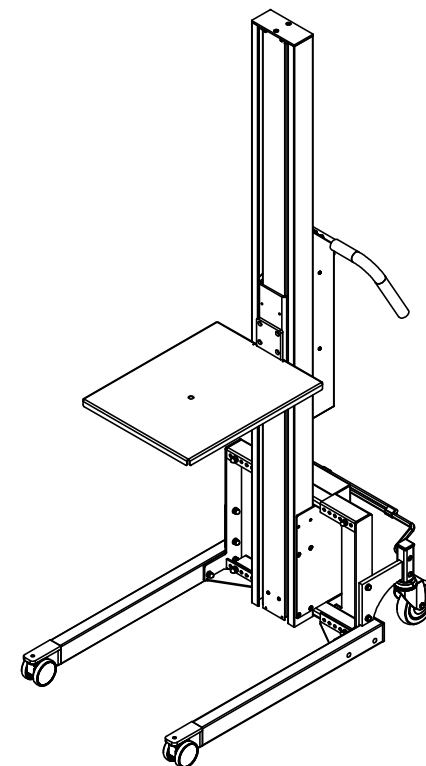

The lift can be ordered with different fixed heights: H, M, L

Add or subtract the ▲-values on the drawing with the number below:

M: 0
L: -400

The tool can be fixed at different height positions.

Add the T-values on the drawing with one of the numbers below:

T₁ = +60
T₀ = +0

Platform EP1 = EP1 + EP2

| | | | |
|---|-------------------------------------|-------------------------|--------------|
| FINISH: | Dimensions: +/- 5 mm | HOVMAND | |
| TITLE: Impact 80M FC1-650-75ds + Platform EP1 | | | |
| MATERIAL: | DWG NO. 110205000000 + Platform EP1 | Revision: 1 | |
| WEIGHT: 60.84 Kg | DRAWN BY: KKP | Date[yy.mm.dd]:20.05.07 | SHEET 1 OF 1 |

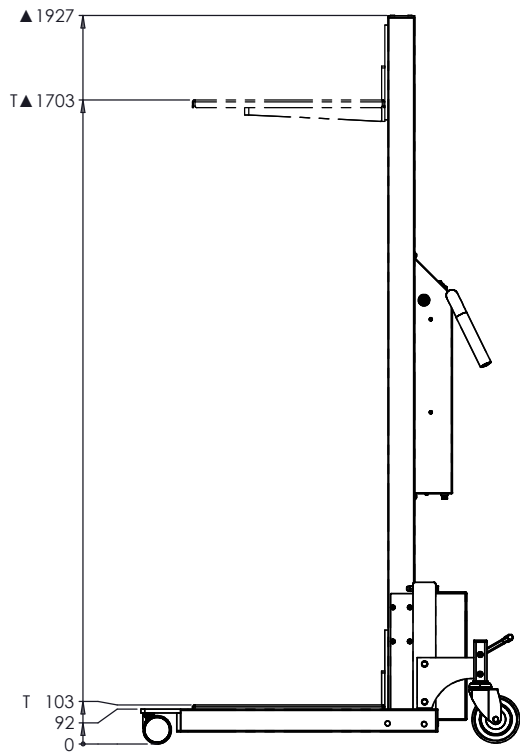

Lifting Stroke: ▲ 1600

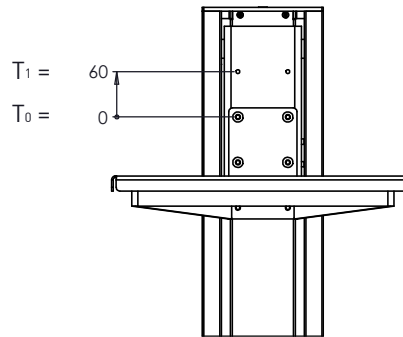

T-values

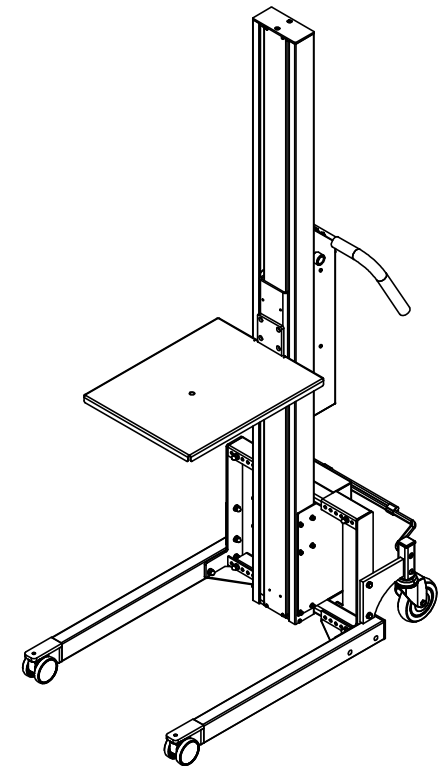

Platform EP = EP1, EP2

The lift can be ordered with different fixed heights: H, M, L

Add or subtract the ▲-values on the drawing with the number below:

H: +400
M: 0
L: -400

The tool can be fixed at different height positions.

Add the T-values on the drawing with one of the numbers below:

T₁ = +60
T₀ = +0

| | | | |
|--|------------------------------------|-------------------------|--------------|
| FINISH: | Dimensions: +/- 5 mm | HOVMAND | |
| TITLE: Impact 90M FC1-650-75ds + Platform EP | | | |
| MATERIAL: | DWG NO. 150205000000 + Platform EP | Revision: 1 | |
| WEIGHT: 60.89 Kg | DRAWN BY: KKP | Date[yy.mm.dd]:20.04.29 | SHEET 1 OF 1 |

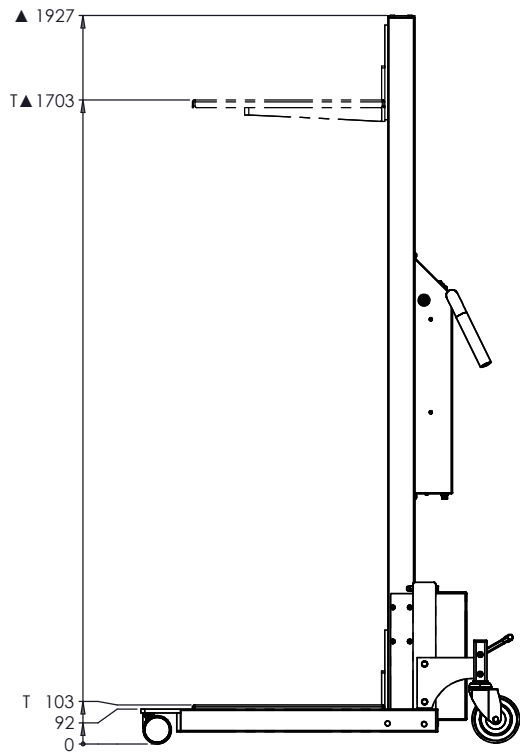

Lifting Stroke: ▲ 1600

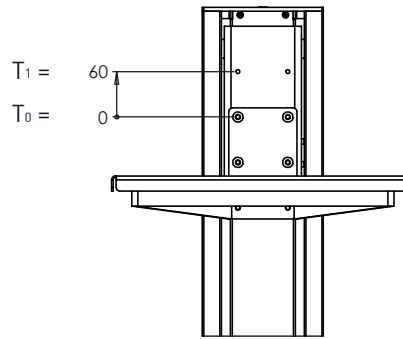

T-values

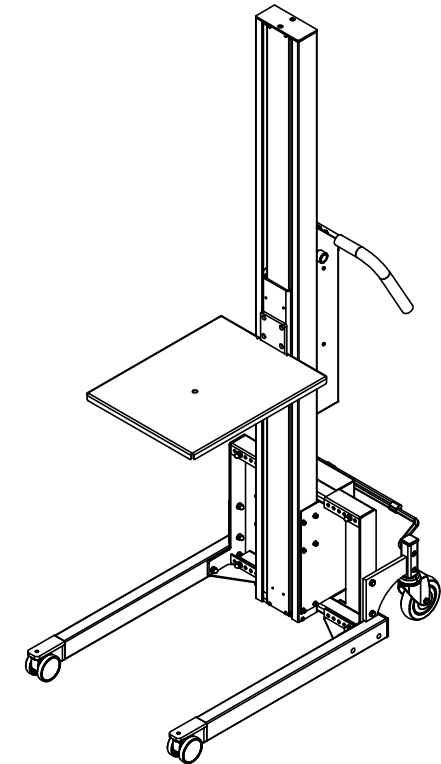

Platform EP = EP1, EP2

The lift can be ordered with different fixed heights: H3, H2, H, M, L
 Add or subtract the ▲-values on the drawing with the number below:
 H3: +1120
 H2: +620
 H: +400
 M: 0
 L: -400

The tool can be fixed at different height positions.
 Add the T-values on the drawing with one of the numbers below:
 T₁ = +60
 T₀ = +0

| | | | |
|---|---|-------------------------|--------------|
| FINISH: | Dimensions: +/- 5 mm | HOVMAND | |
| TITLE: Impact 130M FC1-650-75ds + Platform EP | | | |
| MATERIAL: | DWG NO. 22021108000 + Platform EP 22021108000 + Platform EP | Revision: 1 | |
| WEIGHT: 65.67 Kg | DRAWN BY: KKP | Date[yy.mm.dd]:20.04.29 | SHEET 1 OF 1 |